

# ShaftWall

Shaft and duct encasement system

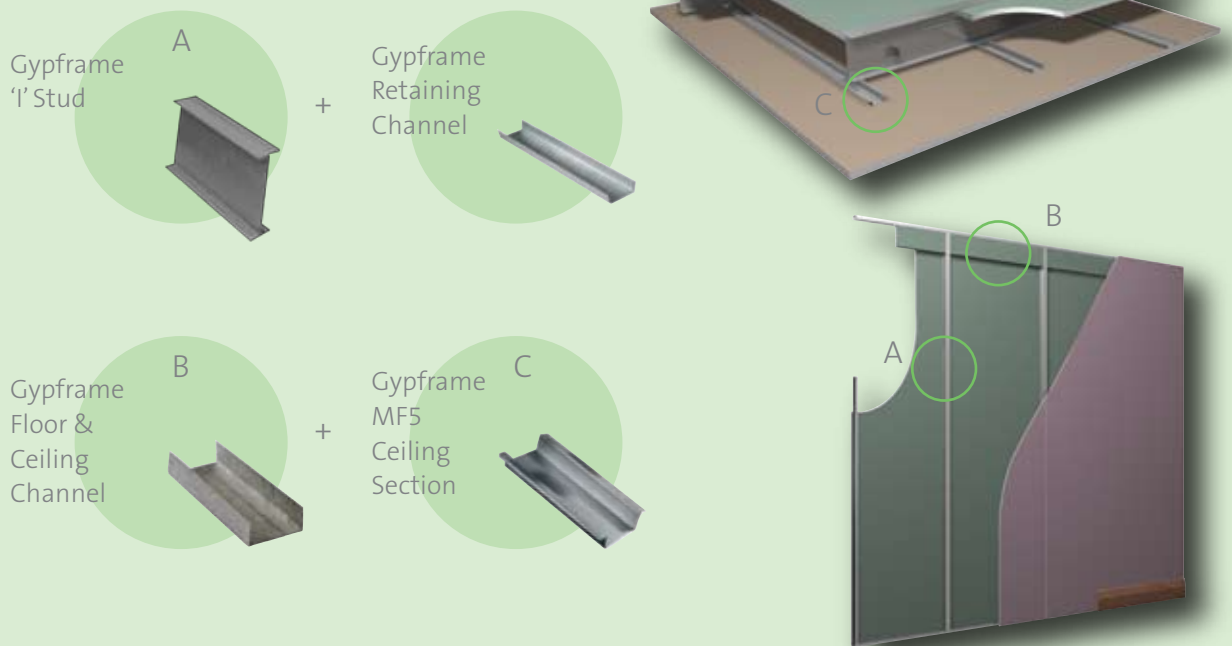

**ShaftWall** provides a lightweight, fire-resistant structure to protect elements in confined spaces wherever access is limited to one side only. The system provides a protective structure which can be incorporated at an early stage of the construction without the need for scaffolding. The system can also be built horizontally to provide a fire-rated membrane. StairWall is a derivative of the ShaftWall system, which is used to protect stairwells.



## Key facts

- Lightweight, fast-track construction
- Provides fire protective shaft enclosures, stairwells and horizontal membranes
- A solution for all enclosures and risers where access is limited to one side only
- Horizontal membranes built entirely from below
- Installation can commence earlier in construction
- Minimal wall thickness of 87mm
- Satisfies deflection and air pressure requirements

## Applications

Service risers, lift shafts, service ducts and stairwells.

## Sector

- ✓ Office / commercial
- ✓ Retail
- ✓ Healthcare
- ✓ Apartment buildings
- ✓ High-rise multi-occupancy

# ShaftWall

## System components

### Gypframe metal products

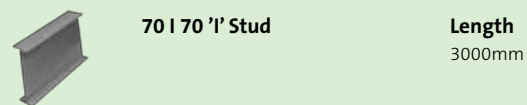

**70 | 70 'I' Stud**      **Length**  
3000mm

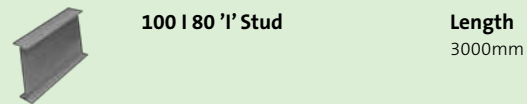

**100 | 80 'I' Stud**      **Length**  
3000mm

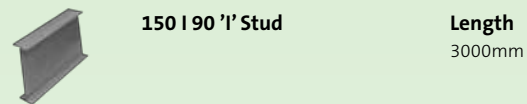

**150 | 90 'I' Stud**      **Length**  
3000mm

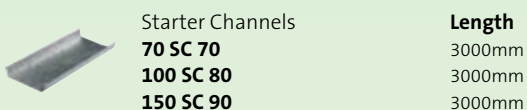

**Starter Channels**      **Length**  
**70 SC 70**      3000mm  
**100 SC 80**      3000mm  
**150 SC 90**      3000mm

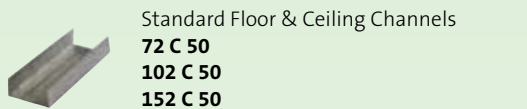

**Standard Floor & Ceiling Channels**  
**72 C 50**  
**102 C 50**  
**152 C 50**

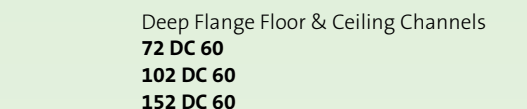

**Deep Flange Floor & Ceiling Channels**  
**72 DC 60**  
**102 DC 60**  
**152 DC 60**

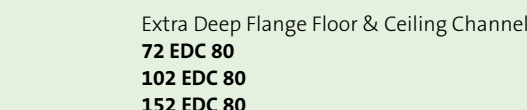

**Extra Deep Flange Floor & Ceiling Channels**  
**72 EDC 80**  
**102 EDC 80**  
**152 EDC 80**

All channels are available in 3000mm.

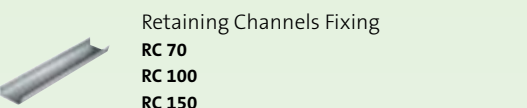

**Retaining Channels Fixing**  
**RC 70**  
**RC 100**  
**RC 150**

All channels are available in 3000mm.

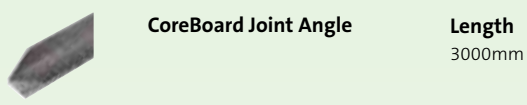

**CoreBoard Joint Angle**      **Length**  
3000mm

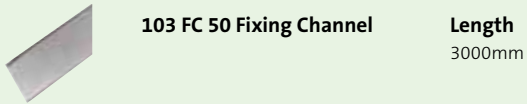

**103 FC 50 Fixing Channel**      **Length**  
3000mm

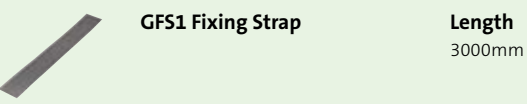

**GFS1 Fixing Strap**      **Length**  
3000mm

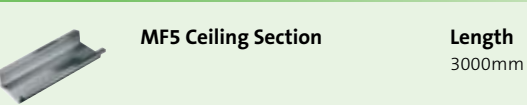

**MF5 Ceiling Section**      **Length**  
3000mm

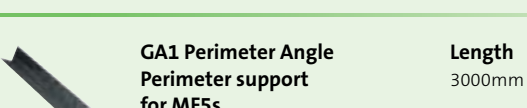

**GA1 Perimeter Angle**      **Length**  
**Perimeter support**      3000mm  
**for MF5s**

### Board products



**Gyproc FireStop<sup>1</sup>**  
**Thickness**      12.5, 15mm  
**Width**      1200mm

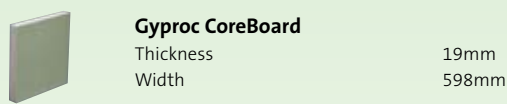

**Gyproc CoreBoard**  
**Thickness**      19mm  
**Width**      598mm

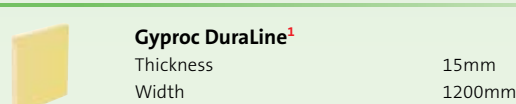

**Gyproc DuraLine<sup>1</sup>**  
**Thickness**      15mm  
**Width**      1200mm

<sup>1</sup> Moisture resistant (MR) versions of the above boards are specified in intermittent wet use areas, e.g. shower cubicles.

### Fixing and finishing products

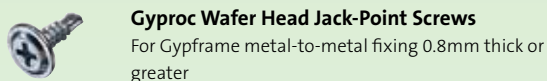

**Gyproc Wafer Head Jack-Point Screws**  
For Gypframe metal-to-metal fixing 0.8mm thick or greater

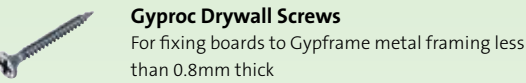

**Gyproc Drywall Screws**  
For fixing boards to Gypframe metal framing less than 0.8mm thick

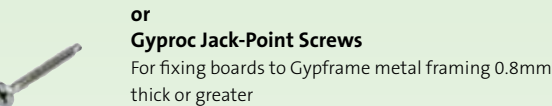

**or Gyproc Jack-Point Screws**  
For fixing boards to Gypframe metal framing 0.8mm thick or greater

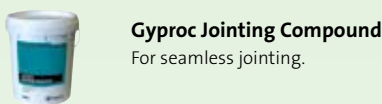

**Gyproc Jointing Compound**  
For seamless jointing.

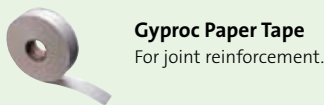

**Gyproc Paper Tape**  
For joint reinforcement.

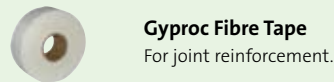

**Gyproc Fibre Tape**  
For joint reinforcement.

### Insulation products

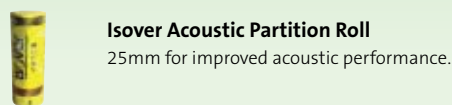

**Isover Acoustic Partition Roll**  
25mm for improved acoustic performance.

Eligible for the SpecSure warranty from Gyproc





## Installation overview

Gypframe Floor & Ceiling Channel is fixed to the structure and Gypframe Starter Channel to vertical abutments. (Please reference to the relevant performance tables for head channels) where required Firestrip is used in a continuous line to seal at the head.

**ShaftWall** is assembled from the non-shaft side using Gypframe 'I' Stud framing. Gyproc CoreBoard is located between studs and secured using Gypframe Retaining Channel. All horizontal joints in the Gyproc CoreBoard layer are fire-stopped. Gyproc FireStop board linings are fixed to the non-shaft side of the frame. Deflection is accommodated at the head by incorporating plasterboard fire-stops cut on site. If specified, 25mm Isover APR is included in the cavity to enhance the acoustic performance.

Pressurised shafts and service ducts are sealed using sealant. This is applied to all board-to-metal junctions.

## Services

Penetrations for services, ducting and access panels require the construction of a framed opening. Fire-stopping is installed by specialist contractors.



# ShaftWall

Table 1 – ShaftWall (vertical elements) - Solutions to satisfy the requirements of BS 476: Part 22: 1987

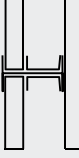
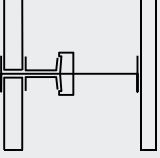
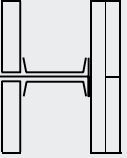
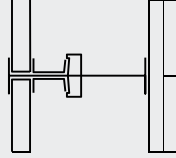
1		<p>Gyproframe 70 or 100mm 'I' Stud framework with Gyproc CoreBoard between studs, secured by Gyproframe Retaining Channel. 25mm Isover APR 1200 in cavity (optional). Lining boards to non-shaft side, see table.</p>
2		<p>Gyproframe 150 I 90 tabbed 'I' Stud framework with Gyproc CoreBoard between studs, secured by Gyproframe Retaining Channel. 25mm Isover APR 1200 in cavity (optional). Lining boards to non-shaft side, see table.</p>
3		<p>Gyproframe 70 or 100mm 'I' Stud framework with Gyproc CoreBoard between studs, secured by Gyproframe Retaining Channel. 25mm Isover APR 1200 in cavity (optional). Lining boards to non-shaft side, see table.</p>
4		<p>Gyproframe 150 I 90 tabbed 'I' Stud framework with Gyproc CoreBoard between studs, secured by Gyproframe Retaining Channel. 25mm Isover APR 1200 in cavity (optional). Lining boards to non-shaft side, see table.</p>

Detail	Partition thickness mm	Lining boards to non-shaft side <sup>1</sup>		Maximum partition heights <sup>2</sup> mm	Stud size mm	Sound insulation $R_w$ <sup>3</sup>		Duty rating <sup>5</sup>	Approx. weight kg/m <sup>2</sup>	System reference
		Board type	Lining thickness mm			No Insulation dB	Sealed structure <sup>4</sup> plus 25mm Isover APR 1200 dB			
60 minutes fire resistance <span style="border: 1px solid black; border-radius: 50%; padding: 2px;">BS</span>										
1	87	FireStop	1 x 15	4200	70	39	42	Heavy	30	A306001/010
1	117	FireStop	1 x 15	6000	100	40	43	Heavy	31	A306004/011
2	167	FireStop	1 x 15	7700	150	43	46	Heavy	33	A306007
90 minutes fire resistance <span style="border: 1px solid black; border-radius: 50%; padding: 2px;">BS</span>										
3	97	FireStop	2 x 12.5	4400	70	40	44	Severe	39	A306002/012
3	127	FireStop	2 x 12.5	6400	100	45	47	Severe	40	A306005/014
4	177	FireStop	2 x 12.5	7900	150	48	52	Severe	42	A306008/020
120 minutes fire resistance <span style="border: 1px solid black; border-radius: 50%; padding: 2px;">BS</span>										
3	102	FireStop	2 x 15	4500	70	42	45	Severe	43	A306003/023
3	132	FireStop	2 x 15	6700	100	44	46	Severe	44	A306006/025
4	182	FireStop	2 x 15	7900	150	48	50	Severe	46	A306009/028

<sup>1</sup> For improved durability and impact resistance, the outer layer of Gyproc FireStop can be replaced with a layer of 15mm Gyproc DuraLine. On single layer linings this will improve duty rating to Severe Duty.

<sup>2</sup> Based on a limiting deflection of L/240 at 200 Pa.

<sup>3</sup> The acoustic performance figures quoted include **ShaftWall** partitions with deflection heads.

<sup>4</sup> Gyproc CoreBoard and first layer of lining board are bedded onto sealant, as required for pressurised air shafts, in addition to normal sealing.

<sup>5</sup> Estimated rating from non-shaft side only.

<sup>6</sup> The temperature of exposed metal may exceed the requirements of BS 476: Part 22: 1987 within the fire test period, and therefore relaxation should be sought from the approving Authority on the basis that no combustible materials are likely to be stored adjacent to the structure. In situations where the full period of insulation is required, contact the Gyproc Technical Team for further guidance.

**NB** The fire resistance and sound insulation performances are for imperforate partitions, but incorporating deflection heads, with all joints taped and filled, according to Gyproc recommendations. The quoted performances are achieved only if Gyproc components are used throughout, and the company's fixing recommendations are strictly observed. Any variation in the specifications should be checked with Gyproc.

**NB** For heights up to 4200mm Gyproframe Floor & Ceiling Channel should be used at the base and Gyproframe Deep Flange Floor & Ceiling Channel at the head. For heights between 4200mm and 8000mm Gyproframe Deep Flange Floor & Ceiling Channel should be used at the head and base. For heights in excess of 8000mm Gyproframe Extra Deep Flange Floor & Ceiling Channel should be used at base and at head (subject to deflection criteria).

**Table 2 – StairWall (vertical elements) - Solutions to satisfy the requirements of BS 476: Part 22: 1987**

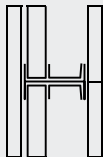
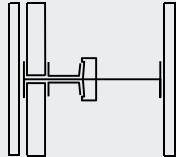
<p>1</p>  <p>Gypframe 70 or 100mm 'I' Stud framework with Gyproc CoreBoard between studs, secured by Gyproc Retaining Channel. 25mm Isover APR 1200 in cavity (optional). Lining boards to both sides, see table.</p>	<p>2</p>  <p>Gypframe 150 I 90mm sabbed 'I' Stud framework with Gyproc CoreBoard between studs, secured by Gyproc Retaining Channel. 25mm Isover APR 1200 in cavity (optional). Lining boards to both sides, see table.</p>
--	--

Detail	Partition thickness mm	Lining boards to non-shaft side <sup>1</sup>		Maximum partition heights <sup>2</sup> mm	Stud size mm	Sound insulation R <sub>w</sub> <sup>3</sup>		Duty rating <sup>5</sup>	Approx. weight kg/m <sup>2</sup>	System reference
		Board type	Lining thickness mm			No Insulation dB	Sealed structure <sup>4</sup> plus 25mm Isover APR 1200 dB			
<b>90 minutes fire resistance BS</b>										
1	97	FireStop	1 x 12.5	4400	70	42	45	Medium	39	A306046/048
1	127	FireStop	1 x 12.5	6100	100	44	48	Medium	40	A306046/048
2	177	FireStop	1 x 12.5	7900	150	48	50	Medium	42	A306046/048
<b>120 minutes fire resistance BS</b>										
1	102	FireStop	1 x 15	4400	70	42	47	Heavy	43	A306047/049
1	132	FireStop	1 x 15	6500	100	45	49	Heavy	44	A306047/049
2	182	FireStop	1 x 15	7900	150	48	50	Heavy	46	A306047/049

<sup>1</sup> For improved durability and impact resistance, Gyproc FireStop can be replaced with a layer of 15mm Gyproc DuraLine. On single layer linings this will improve duty rating to Severe Duty.  
<sup>2</sup> Based on a limiting deflection of L/240 at 200 Pa.  
<sup>3</sup> The acoustic performance figures quoted include StairWall partitions with deflection heads.  
<sup>4</sup> Gyproc CoreBoard and first layer of lining board are bedded onto sealant, as required for pressurised air shafts, in addition to normal sealing.  
<sup>5</sup> Estimated rating.

**NB** The fire resistance and sound insulation performances are for imperforate partitions, but incorporating deflection heads, with all joints taped and filled, according to Gyproc recommendations. The quoted performances are achieved only if Gyproc components are used throughout, and the company's fixing recommendations are strictly observed. Any variation in the specifications should be checked with Gyproc.

**NB** For heights up to 4200mm Gypframe Floor & Ceiling Channel should be used at the base and Gypframe Deep Flange Floor & Ceiling Channel at the head. For heights between 4200mm and 8000mm Gypframe Deep Flange Floor & Ceiling Channel should be used at the head and base. For heights in excess of 8000mm Gypframe Extra Deep Flange Floor & Ceiling Channel should be used at base and at head (subject to deflection criteria).

# ShaftWall

Table 3 – ShaftWall (horizontal elements) - Solutions to satisfy the requirements of BS 476: Part 22: 1987

1		2	
<p>Gypframe 70 or 100mm 'I' Stud or Gypframe 150 I 90 tabbed 'I' Stud frames with Gyproc CoreBoard between studs, secured by Gypframe Retaining Channel. 25mm Isover APR 1200 in cavity (optional). Gypframe MF5 Ceiling Sections fixed to ceiling side at 450mm centres. Lining boards to ceiling side, see table.</p>		<p>Two Gypframe 150 I 90 tabbed 'I' Stud frames with Gyproc CoreBoard between studs, secured by Gypframe Retaining Channel. 25mm Isover APR 1200 in cavity (optional). On the lower framework only, Gypframe MF5 Ceiling Sections fixed to ceiling side at 450mm centres. Lining boards to ceiling side, see table.</p>	
3			
<p>Two Gypframe 150 I 90 tabbed 'I' Stud frames with Gyproc CoreBoard between studs, secured by Gypframe Retaining Channel. 25mm Isover APR 1200 in cavity (optional). On the lower framework only, Gypframe MF5 Ceiling Sections fixed to ceiling side at 450mm centres. Lining boards to ceiling side, see table.</p>			

Detail	Membrane thickness mm	Lining boards to ceiling side		Maximum span <sup>1</sup> mm	Stud size mm	Sound insulation R <sub>w</sub>		Approx. weight kg/m <sup>2</sup>	System reference					
		Board type	Lining thickness mm			No Insulation dB	Sealed structure <sup>2</sup> plus 25mm Isover APR 1200 dB							
<b>60 minutes fire resistance</b> <span style="border: 1px solid black; border-radius: 50%; padding: 2px;">BS</span>														
1	124	FireStop	2 x 15	2800	70	42	45	39	C106053					
1	154	FireStop	2 x 15	3700	100	44	46	39	C106054					
1	204	FireStop	2 x 15	5100	150	48	50	39	C106055					
<b>90 minutes fire resistance</b> <span style="border: 1px solid black; border-radius: 50%; padding: 2px;">BS</span>														
2	391	<table border="0" style="font-size: 2em; vertical-align: middle;"> <tr> <td style="font-size: 1.5em;">{</td> <td>FireStop upper frame</td> <td>1 x 15</td> </tr> <tr> <td style="font-size: 1.5em;">}</td> <td>FireStop lower frame</td> <td>2 x 15</td> </tr> </table>	{	FireStop upper frame	1 x 15	}	FireStop lower frame	2 x 15	5100	150	48	50	77	C106057
{	FireStop upper frame	1 x 15												
}	FireStop lower frame	2 x 15												
<b>120 minutes fire resistance</b> <span style="border: 1px solid black; border-radius: 50%; padding: 2px;">BS</span>														
3	406	<table border="0" style="font-size: 2em; vertical-align: middle;"> <tr> <td style="font-size: 1.5em;">{</td> <td>FireStop upper frame</td> <td>2 x 15</td> </tr> <tr> <td style="font-size: 1.5em;">}</td> <td>FireStop lower frame</td> <td>2 x 15</td> </tr> </table>	{	FireStop upper frame	2 x 15	}	FireStop lower frame	2 x 15	5100	150	48	50	88	C106056
{	FireStop upper frame	2 x 15												
}	FireStop lower frame	2 x 15												

<sup>1</sup> Based on a limiting deflection of L/400.

<sup>2</sup> Gyproc CoreBoard and first layer of lining board are bedded onto sealant, as required for pressurised air shafts, in addition to normal sealing.

**NB** The fire resistance and sound insulation performances are for imperforate ceilings incorporating boards with all joints taped and filled according to Gyproc recommendations. The quoted performances are achieved only if Gyproc components are used throughout, and the company's fixing recommendations are strictly observed. Any variation in the specifications should be checked with Gyproc.



**NB** The fire resistances quoted are for imperforate constructions.

**NB** ShaftWall used horizontally should not be used for materials storage or for access for personnel.

**NB** Gypframe Extra Deep Floor & Ceiling Channel should be used at perimeter.

## Performance (► Refer to Basic principles of system design)

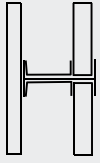
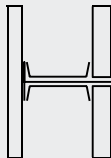
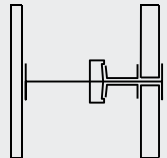
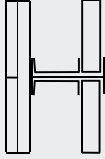
**Table 4a - ShaftWall (vertical elements) - limiting heights at various air pressures and allowable deflections**

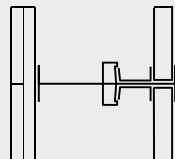
1	 <p>Gypframe 70   70 'I' Stud framework with one layer of 15mm Gyproc FireStop<sup>1</sup>.</p>	2	 <p>Gypframe 100   80 'I' Stud framework with one layer of 15mm Gyproc FireStop<sup>1</sup>.</p>	3	 <p>Gypframe 150   90 tabbed 'I' Stud framework with one layer of 15mm Gyproc FireStop<sup>1</sup>.</p>
4	 <p>Gypframe 70   70 'I' Stud framework with two layers of 12.5mm Gyproc FireStop<sup>1</sup>.</p>	5	 <p>Gypframe 100   80 'I' Stud framework with two layers of 12.5mm Gyproc FireStop<sup>1</sup>.</p>	6	 <p>Gypframe 150   90 tabbed 'I' Stud framework with two layers of 12.5mm Gyproc FireStop<sup>1</sup>.</p>

Detail	System	Allowable deflection	Limiting height (mm) at stated air pressure (Pa)									System reference
			200	240	300	360	400	480	500	600	650	
1	ShaftWall	L/125	5000	4700	4400	4100	4000	3800	3700	3500	3400	A306001/010
		L/240	4200	4000	3700	3500	3300	3200	3100	2900	2800	
		L/360	3700	3500	3300	3100	2900	2800	2700	2600	2500	
2	ShaftWall	L/125	7500	7100	6600	6200	6000	5700	5500	5200	5100	A306004/011
		L/240	6000	5700	5300	5000	4800	4600	4400	4200	4100	
		L/360	5200	4900	4600	4300	4200	4000	3900	3600	3500	
3	ShaftWall	L/125	9600	9000	8400	7900	7600	7200	7100	6700	6500	A306008/020
		L/240	7700	7300	6700	6400	6100	5800	5700	5400	5200	
		L/360	6700	6400	5900	5500	5400	5000	5000	4700	4600	
4	ShaftWall	L/125	5200	4900	4600	4300	4200	4000	3800	3600	3500	A306002/012
		L/240	4400	4100	3800	3600	3500	3300	3200	3000	2900	
		L/360	3800	3600	3300	3100	3000	2900	2800	2600	2500	
5	ShaftWall	L/125	7900	7400	6900	6500	6300	5900	5800	5500	5300	A306005/014
		L/240	6400	6000	5600	5200	5000	4800	4700	4400	4300	
		L/360	5600	5200	4900	4600	4400	4200	4100	3900	3800	
6	ShaftWall	L/125	9800	9200	8600	8100	7800	7500	7200	6800	6600	A306008/020
		L/240	7900	7400	6900	6500	6200	6000	5800	5500	5300	
		L/360	6900	6500	6000	5600	5500	5200	5100	4800	4600	

**Table 4a** gives the limiting heights for **ShaftWall** systems when subjected to air pressures ranging from 200 Pa through to 650 Pa and at three allowable deflection levels - L/125, L/240, L/360. Partition heights are normally quoted for air pressures of 200 Pa at an allowable deflection of L/240. Refer to **Limiting heights at different air pressures**, in **Design** section.

<sup>1</sup> Gyproc FireStop can be replaced with Gyproc DuraLine.

**NB** For heights up to 4200mm Gypframe Floor & Ceiling Channel should be used at the base and Gypframe Deep Flange Floor & Ceiling Channel at the head. For heights between 4200mm and 8000mm Gypframe Deep Flange Floor & Ceiling Channel should be used at the head and base. For heights in excess of 8000mm Gypframe Extra Deep Flange Floor & Ceiling Channel should be used at base and at head (subject to deflection criteria).

# ShaftWall

Table 4b - ShaftWall (vertical elements) - limiting heights at various air pressures and allowable deflections

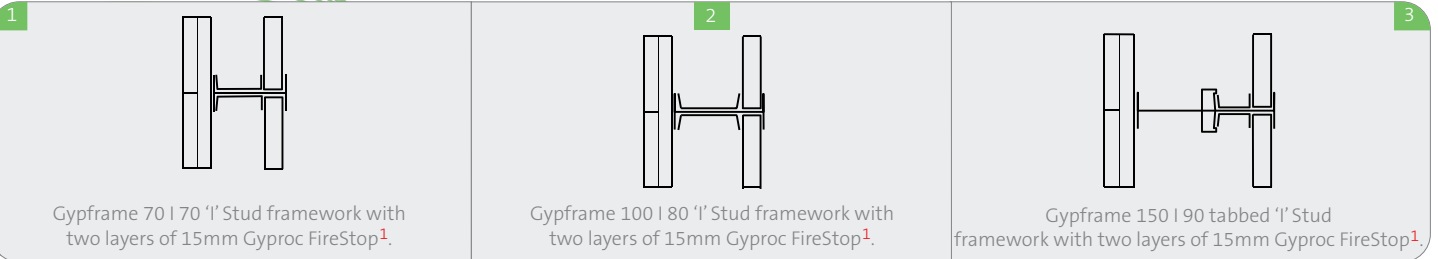

Detail	System	Allowable deflection	Limiting height (mm) at stated air pressure (Pa)									System reference
			200	240	300	360	400	480	500	600	650	
1	ShaftWall	L/125	5200	4900	4600	4300	4100	4000	3800	3600	3500	
		L/240	4500	4200	3900	3700	3500	3400	3300	3100	3000	A306003/023
		L/360	3900	3700	3400	3200	3100	3000	2900	2700	2600	
2	ShaftWall	L/125	8400	7900	7300	6900	6600	6400	6200	5800	5600	
		L/240	6700	6300	5900	5500	5300	5100	5000	4700	4500	A306006/025
		L/360	5600	5300	4900	4600	4500	4300	4100	3900	3800	
3	ShaftWall	L/125	9900	9300	8600	8100	7800	7500	7200	6800	6600	
		L/240	7900	7400	6900	6500	6300	6000	5800	5500	5300	A306009/028
		L/360	6900	6500	6000	5700	5500	5300	5100	4800	4700	

Table 4b gives the limiting heights for ShaftWall systems when subjected to air pressures ranging from 200 Pa through to 650 Pa and at three allowable deflection levels - L/125, L/240, L/360. Partition heights are normally quoted for air pressures of 200 Pa at an allowable deflection of L/240. Refer to **Limiting heights at different air pressures**, in Design section.

<sup>1</sup> Gyproc FireStop can be replaced with Gyproc DuraLine.

**NB** For heights up to 4200mm Gypframe Floor & Ceiling Channel should be used at the base and Gypframe Deep Flange Floor & Ceiling Channel at the head. For heights between 4200mm and 8000mm Gypframe Deep Flange Floor & Ceiling Channel should be used at the head and base. For heights in excess of 8000mm Gypframe Extra Deep Flange Floor & Ceiling Channel should be used at base and at head (subject to deflection criteria).

**Table 4c - ShaftWall (vertical elements) - limiting heights at various air pressures and allowable deflections**

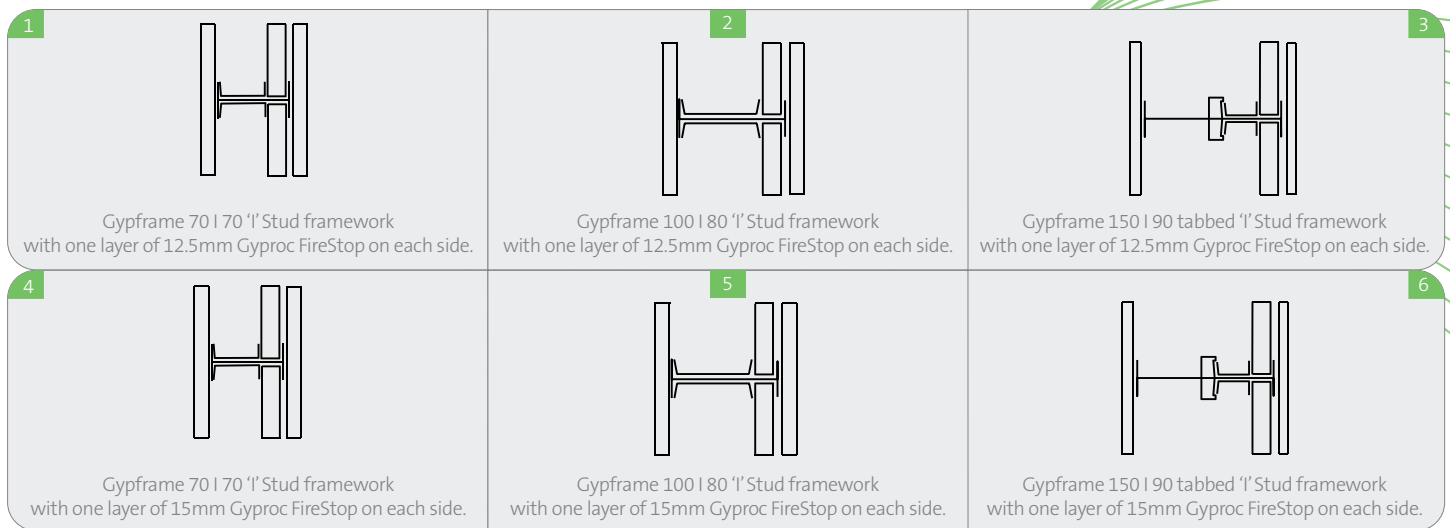

Detail	System	Allowable deflection	Limiting height (mm) at stated air pressure (Pa)									System reference
			200	240	300	360	400	480	500	600	650	
1	ShaftWall	L/125	5300	5000	4700	4400	4200	4100	3900	3700	3600	A306046/048
		L/240	4400	4100	3800	3600	3500	3300	3200	3000	2900	
		L/360	3900	3600	3400	3200	3100	2900	2800	2700	2600	
2	ShaftWall	L/125	7600	7100	6600	6200	6000	5700	5600	5200	5100	A306046/048
		L/240	6100	5700	5300	5000	4800	4500	4500	4200	4100	
		L/360	5300	5000	4600	4300	4200	3900	3900	3700	3600	
3	ShaftWall	L/125	8100	7600	7000	6600	6400	6000	5900	5600	5400	A306046/048
		L/240	6500	6100	5700	5300	5100	4800	4800	4500	4400	
		L/360	5600	5300	4900	4600	4400	4200	4100	3900	3800	
4	ShaftWall	L/125	5400	5000	4700	4400	4200	4100	3900	3700	3600	A306047/049
		L/240	4400	4100	3800	3600	3500	3300	3200	3000	2900	
		L/360	3900	3600	3400	3200	3100	2900	2800	2700	2600	
5	ShaftWall	L/125	9800	9200	8600	8100	7800	7300	7200	6800	6600	A306047/049
		L/240	7900	7400	6900	6500	6300	5900	5800	5500	5300	
		L/360	6900	6500	6000	5700	5500	5200	5100	4800	4700	
6	ShaftWall	L/125	9800	9200	8600	8100	7800	7300	7200	6800	6600	A306047/049
		L/240	7900	7400	6900	6500	6300	5900	5800	5500	5300	
		L/360	6900	6500	6000	5700	5500	5200	5100	4800	4700	

Table 4c gives the limiting heights for ShaftWall systems when subjected to air pressures ranging from 200 Pa through to 650 Pa and at three allowable deflection levels - L/125, L/240, L/360. Partition heights are normally quoted for air pressures of 200 Pa at an allowable deflection of L/240. Refer to **Limiting heights at different air pressures**, in **Design** section.

1 Gyproc FireStop can be replaced with Gyproc DuraLine.

**NB** For heights up to 4200mm Gypframe Floor & Ceiling Channel should be used at the base and Gypframe Deep Flange Floor & Ceiling Channel at the head. For heights between 4200mm and 8000mm Gypframe Deep Flange Floor & Ceiling Channel should be used at the head and base. For heights in excess of 8000mm Gypframe Extra Deep Flange Floor & Ceiling Channel should be used at base and at head (subject to deflection criteria).

## Design

### Planning - key factors

The position of services should be pre-determined and their installation planned into the frame erection stage. Timber sole plates should be considered, where allowed, where the floor is uneven.

### Refer to Service installations.

It is important that a good standard of control is exercised on site to ensure that the adoption of drylining techniques at such an early stage of construction is fully integrated into the planning and site progress. If the building envelope is left unsealed while **ShaftWall** or **StairWall** is under construction, Gyproc FireStop **MR** or Gyproc DuraLine **MR** should be used for the lining. All penetrations will need to be adequately fire-stopped.

### Limiting heights at different air pressures

The maximum heights quoted in the performance tables are based on a limiting deflection of L/240 at 200 Pa. In practice, deflection from L/125 to L/360 may be allowed and pressure conditions between 200 Pa and 650 Pa may be encountered. These variations will affect the maximum wall height. Refer to Tables 4a, 4b and 4c.

### Deflection criteria

Partitions built to a maximum height based on L/125 at 200 Pa will exhibit greater deflection compared to partitions built to a maximum height based on L/240 at 200 Pa. Partitions with deflection characteristics outside the standard L/240 criteria will exhibit more flex during installation and in general use, and therefore we recommend you verify the acceptability of the deflections with the relevant interested parties before specifying / installing partitions based on L/125 criteria.

### Connection to the structure

Structural steelwork and its associated connections often result in complex junctions around shafts. If **ShaftWall** or **StairWall** is built on the same line as the beamwork framing the shaft, problems may arise in trying to seal the wall up to the steelwork. It is recommended that, wherever possible, the wall should be located to one side of the beams, and fixed from structural floor to structural soffit.

### Fixing the floor channel

The floor channel must have continuous support along its length to maintain specified performance levels. If continuous support is not provided by the structure, e.g. Z-sections running transverse to a steel beam, the designer should detail the installation of a rigid non-combustible material between the Z-sections. In situations where the floor channel is fixed to diagonal structural steel, the studs should be accurately scribed to the rake of the channel to maintain the full bearing surface.

### Fixing to metal decking

Where **ShaftWall** or **StairWall** is to be located transverse to the profiles of the decking, all slots or perforations above the head channel should be sealed using a proprietary fire barrier or fire spray. Fire-stopping material can be applied prior to the head channel being positioned, providing that any surplus is removed flush with the steel decking.

### Fixing to fire-sprayed and stone mineral wool protected structural steel

If it should be necessary to build the wall on the line of steel beams, then a method must be used to minimise the disruption of the fire protection.

Z-section, with a depth equal to the thickness of the fire protection being applied, should be fixed to the beam at maximum 600mm centres prior to application of the fire protection.

The dimensions of the Z-section should be determined by the designer, but as a guide should not be less than 2mm gauge steel. The applied fire protection incorporating the Z-section should then provide a continuous fire-stopped support above the head channel of the **ShaftWall** or **StairWall** when this is secured into position (see **Construction details – 24**). The head channel should be securely fixed to each Z-section using two Gyproc Wafer Head Jack-Point Screws. Where it is necessary to fix Z-sections to previously fire protected beams, making good above the head channel and around the Z-sections is essential.

### Fixing to structural steel encasements

Where **ShaftWall** abuts a column or beam encasement, the framing will generally require fixing to the structural steelwork.

Where **ShaftWall** abuts the web of the steelwork a Z-section can be located to provide a fixing point level with the flanges of the steelwork.

### Off-set fixing

Where **ShaftWall** is off the line of the steelwork or supporting structure, it can be cantilevered back using Z-section or flat steel plate as determined by the designer. These will require separate fire protection to maintain the fire performance of the system.

### Wall positioned adjacent to steel beams

Where **ShaftWall** abuts the floor decking adjacent to a steel beam, provision will be required to maintain fire protection of the composite structure, e.g. filling voids at head of partition with suitable fire-stopping materials.

### Pressurised airshafts and service ducts

The use of pressure conditions in various types of shaft / duct requires that the boards should be sealed into the framing members using sealant in addition to the normal sealing of the framing to adjoining structures. It is essential that these areas are identified at a very early stage of the contract, and that other trades are instructed to recognise the need for the application of sealant and its replacement if subsequently damaged or removed.

In order that the integrity of the pressurised system can be maintained, sealant should be specified for all board-to-metal applications, and the sealing of Gyproc CoreBoard to the framing (see **Construction details – 19 - 22**).

## Design

### Deflection heads

Deflection heads, by definition, must be able to move and, therefore, achieving an airtight seal is difficult. Inevitably, this will have a detrimental effect on the acoustic performance of any wall that incorporates deflection at the head. In most cases, a suspended ceiling will assist in minimising loss of performance. Standard head details are shown in **Construction details – 11-14**. Firestrip must be applied as a continuous seal where indicated to maintain fire performance. Also, board fixings must not be inserted above the uppermost line depicted by the red arrow in each drawing. Where greater deflection needs to be accommodated, contact the Gyproc Technical Team for further guidance.

### Control joints

Control joints may need to be considered in conditions where excessive movement is likely to occur, or to coincide with constructional expansion joints. In order that the deflection criteria can be maintained throughout the building, it is necessary to introduce horizontal movement joints in the lining where this would normally be required to extend through the height of the building, e.g. stairwells.

The horizontal movement joint can be accommodated adjacent to the floor slab (see **Construction details – 30**).

### Doors

In the case of both normal access doors and lift doors, the door and frame assembly must have been shown by a fire resistance test to achieve the required standard of performance in this form of construction.

Lift doors must be substantiated in conjunction with ShaftWall complete with their framing members and transom panels. To achieve a satisfactory level of compatibility, a suitable starter channel should be mechanically fixed to the door frame at 300mm centres (see **Construction details – 21**).

### Access for maintenance

For access doors, openings should be framed to avoid impairing the structural or fire-resistant properties of **ShaftWall**. To provide an opening ready to receive a door set, the jambs to storey height should be capped with Gypframe Channel incorporating a plasterboard packer. A pre-formed spandrel panel assembled between starter channels (see **Construction details – 20**) should be inserted between jambs and engaged into the head channel, retaining the 15mm gap for deflection at the head. Support is provided by a Gypframe Channel transom. The door frame is secured to both Gypframe 'I' Stud and Gypframe Channel jambs and also to the transom member (see **Construction details – 22**).

### Service penetrations

Penetrations of fire-resistant constructions for services need careful consideration to ensure that the integrity of the element is not impaired, and also that the

services themselves do not act as the mechanism of fire spread.

Refer to **Service installations**.

### Independent support

When designing for the installation of services such as fire dampers and associated ductwork through a **GypWall** partition, consideration should be given to the size and weight of the damper – this will determine whether it can be supported directly from the partition or needs to be independently supported from the structure.

Refer to **Service installations**.

### Opening bridging studs

Openings should be constructed using channels for the trimming members. The web of the channel should be rebated to allow the flanges to oversail the stud. The flanges are secured with two fixings. Channels are cut and inserted to maintain the 25mm gap surround and fixed to the trimming channels (see **Construction details – 18**).

### Opening between studs

The opening is constructed using channels for the trimming members. The web should be rebated and the flanges allowed to oversail the studs. The stud is secured with two fixings. Channels are cut and inserted with the webs folded to provide fixings. A plasterboard packer is inserted adjacent to the stud.

### Electrical services

The positions for light switches and other electrical outlets should be pre-determined in order that provision can be made for support, and also for the fire integrity of the system. Gypframe 103 FC 50 Fixing Channel should be cut to bridge adjoining studs, with the edges flattened to permit fixing. The fixing channel should be backed with stone mineral wool. Gyproc FireStop linings should be cut to allow a close fitting entry of the switch box which can be secured to the fixing channel (see **Construction details – 7**). Back switch boxes with stone mineral wool to maintain fire integrity.

### Horizontal ShaftWall

**ShaftWall** can be specified for horizontal applications as a free-spanning membrane with no support from the soffit. The membrane can be constructed entirely from below and can achieve spans up to 5100mm and fire resistance up to 120 minutes. A typical application is for fire escape corridors.

Supporting partitions should be of at least the same fire resistance period as the horizontal ShaftWall. Specifications for horizontal ShaftWall are complex and detailed, and therefore enquiries should be directed to the Gyproc Technical Team.

### Board finishing

Refer to **Finishing systems**.

# ShaftWall

## Construction details

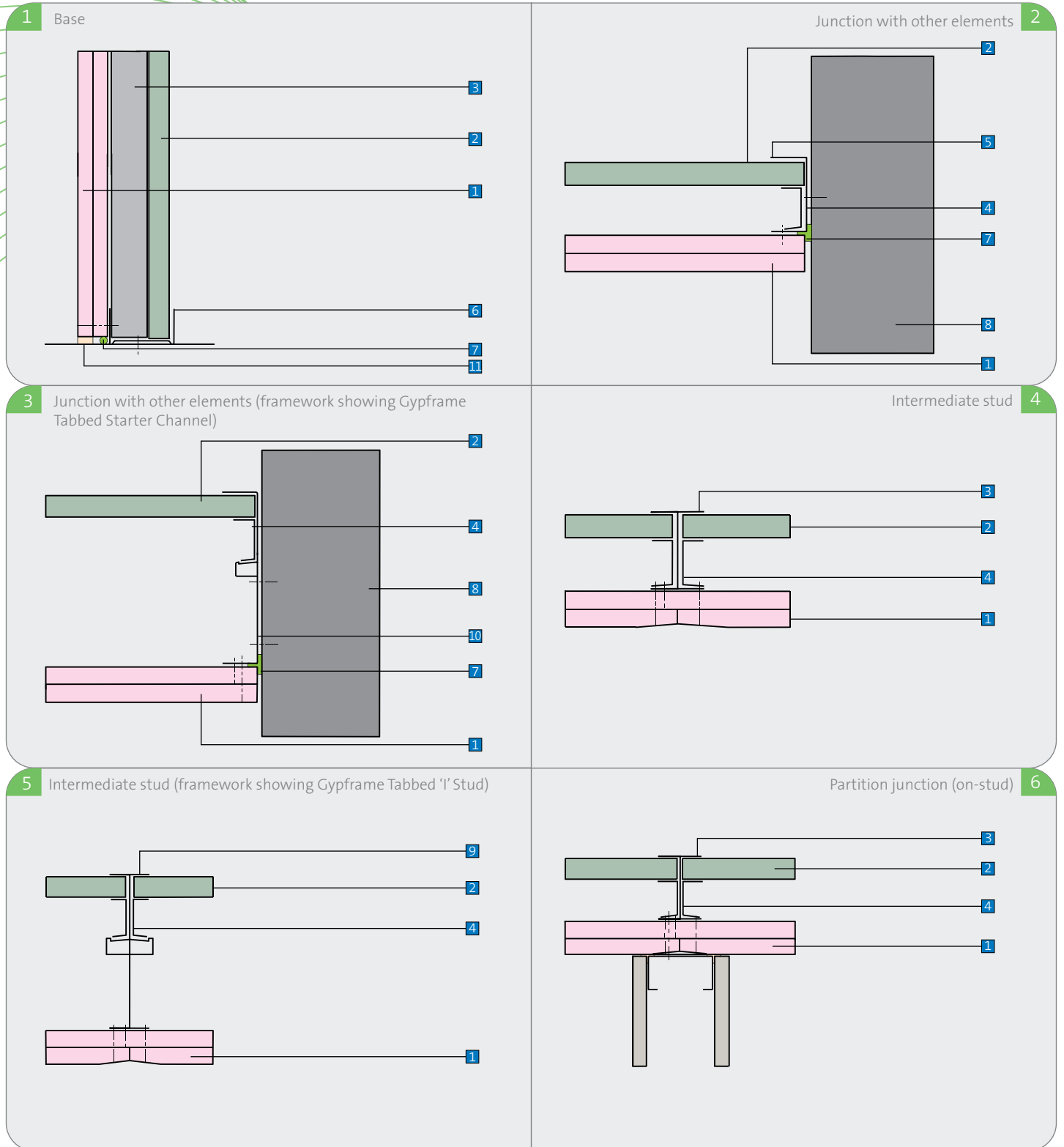

- 1 Gyproc FireStop
- 2 Gyproc CoreBoard
- 3 Gypframe 'I' Stud
- 4 Gypframe Retaining Channel
- 5 Gypframe Starter Channel
- 6 Gypframe Standard Floor & Ceiling Channel

- 7 Sealant
- 8 Structure
- 9 Gypframe 150 I 90 tabbed 'I' Stud
- 10 Gypframe 150 SC 90 tabbed Starter Channel
- 11 Bulk fill with Gyproc jointing materials (where gap exceeds 5mm)

## Construction details

7 Socket box

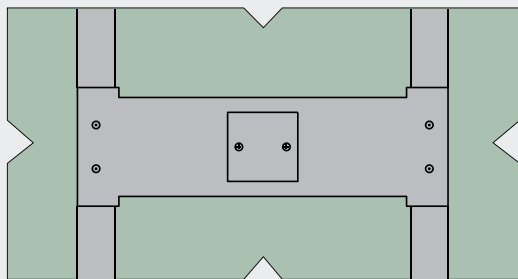
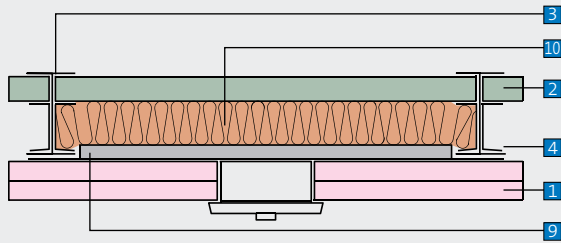

Horizontal Gyproc CoreBoard joints

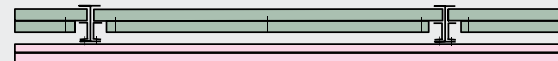
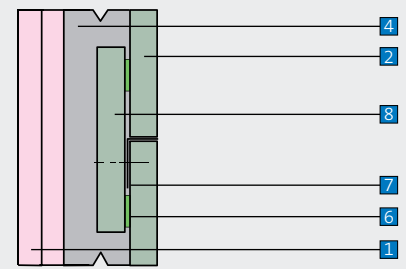

Internal corner

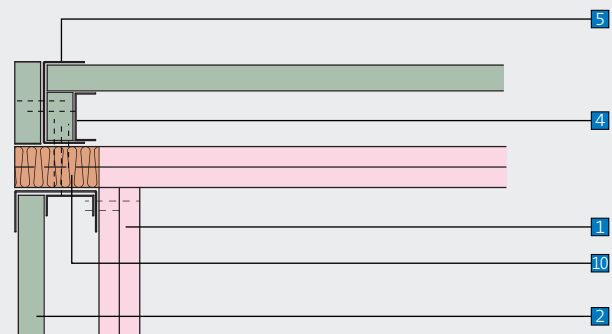

10 External corner

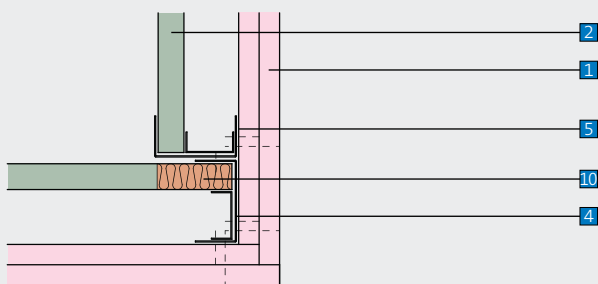

- 1 Gyproc FireStop
- 2 Gyproc CoreBoard
- 3 Gypframe 'I' Stud
- 4 Gypframe Retaining Channel
- 5 Gypframe Starter Channel

- 6 Sealant
- 7 Gypframe CoreBoard Joint Angle
- 8 Gyproc CoreBoard strip (cut on site)
- 9 Gypframe 103 FC 50 Fixing Channel
- 10 Stone mineral wool (by others)

# ShaftWall

## Construction details

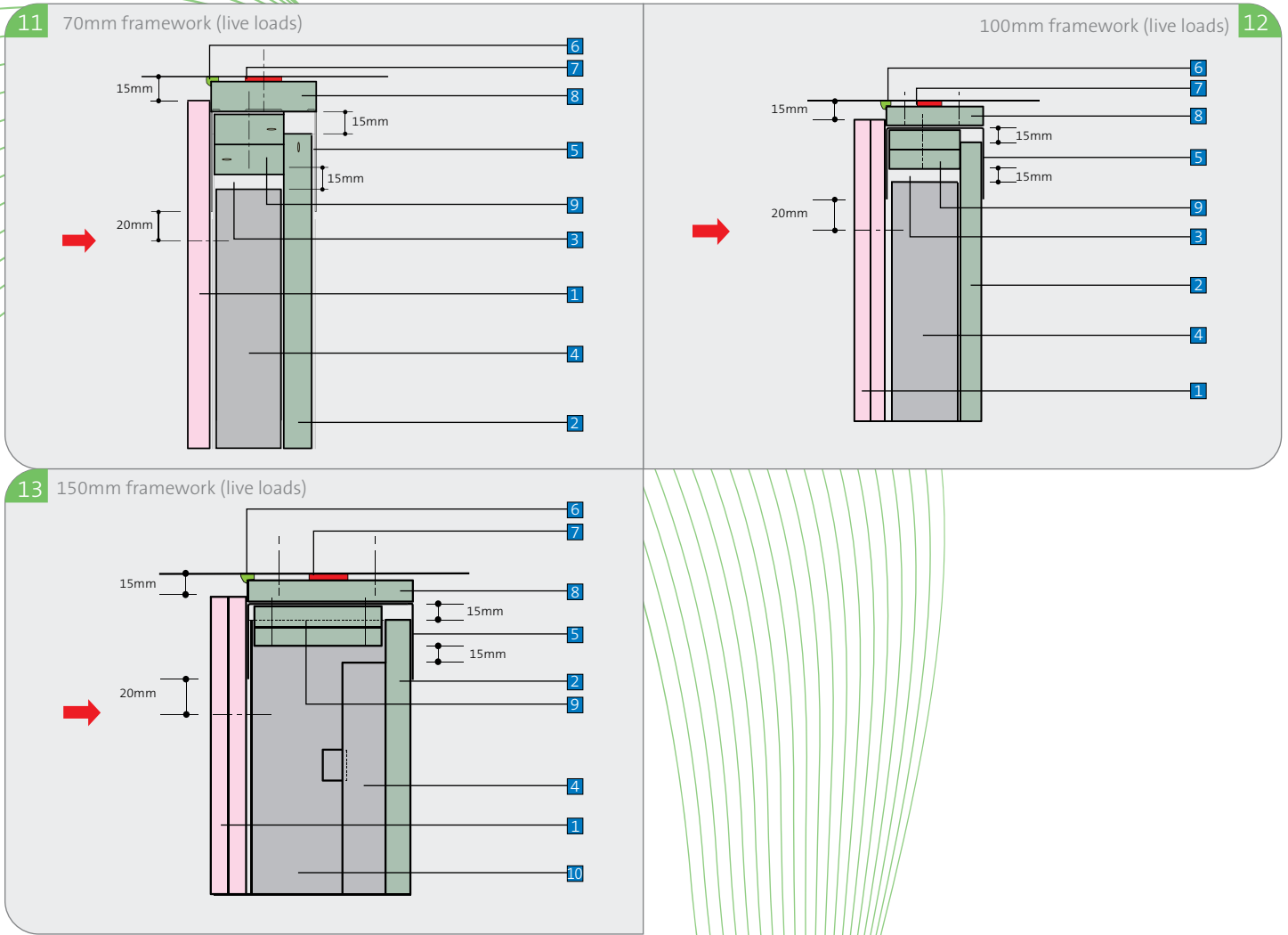

- 1 Gyproc FireStop
- 2 Gyproc CoreBoard
- 3 Gypframe 'I' Studs
- 4 Gypframe Retaining Channel
- 5 Gypframe Extra Deep Flange Floor & Ceiling Channel
- 6 Sealant

- 7 Firestrip
- 8 Gyproc CoreBoard as dropped soffit
- 9 Gyproc CoreBoard fire-stop
- 10 Gypframe 150 I 90 tabbed 'I' Stud

**NB** No fixings should be made through the boards into the flanges of the head channel. The arrow (➔) denotes the position of the uppermost board fixing.

## Construction details

14 Head (sealed structure)

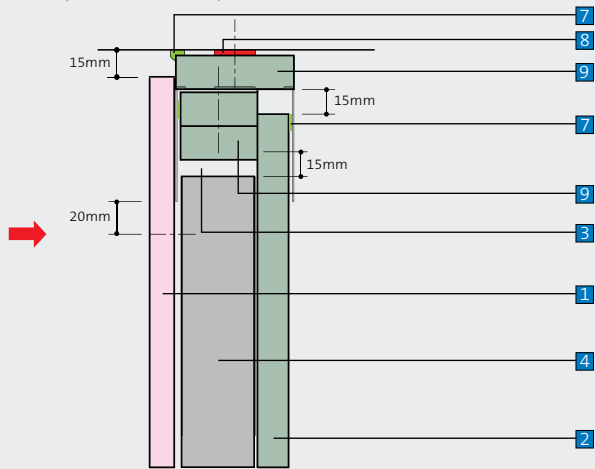

Intermediate stud (sealed structure) 15

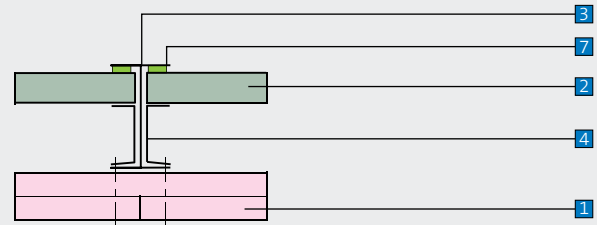

16 Base (sealed structure)

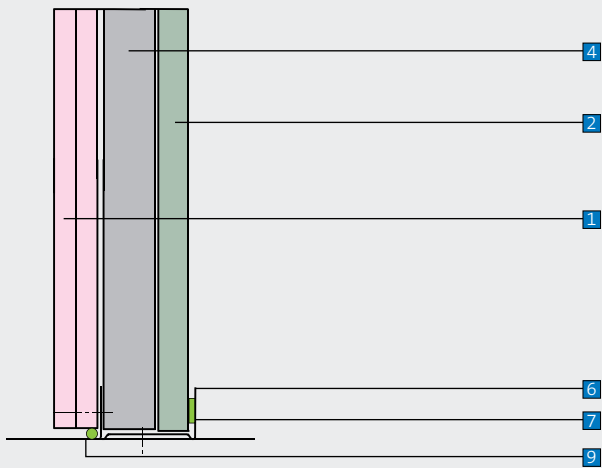

Junction with other elements (sealed structure) 17

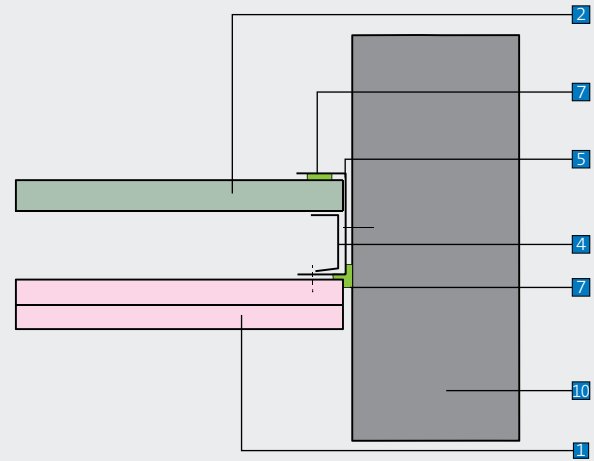

- 1 Gyproc FireStop
- 2 Gyproc CoreBoard
- 3 Gypframe 'I' Stud
- 4 Gypframe Retaining Channel
- 5 Gypframe Starter Channel
- 6 Gypframe Standard Floor & Ceiling Channel
- 7 Sealant

- 8 Firestrip
- 9 Gyproc CoreBoard fire-stop (cut on site)
- 10 Structure

# ShaftWall

## Construction details

### 18 Opening bridging studs

Section W-W

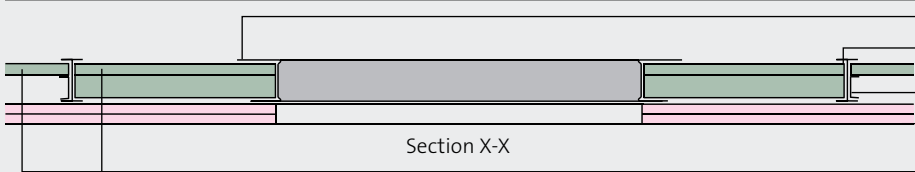
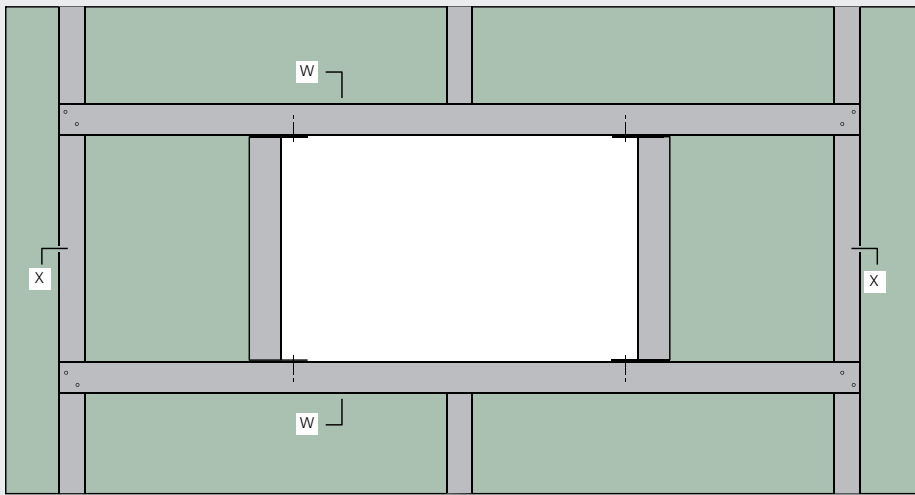

Section X-X

- 6
- 5
- 3
- 4
- 1
- 2

### 19 Opening between studs

Section Y-Y

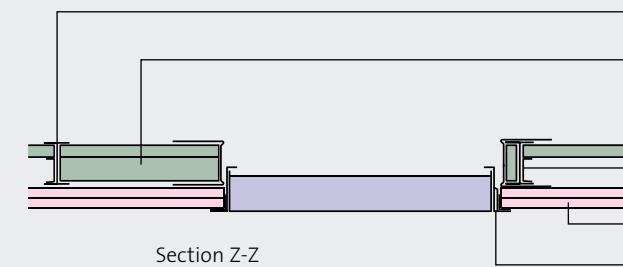
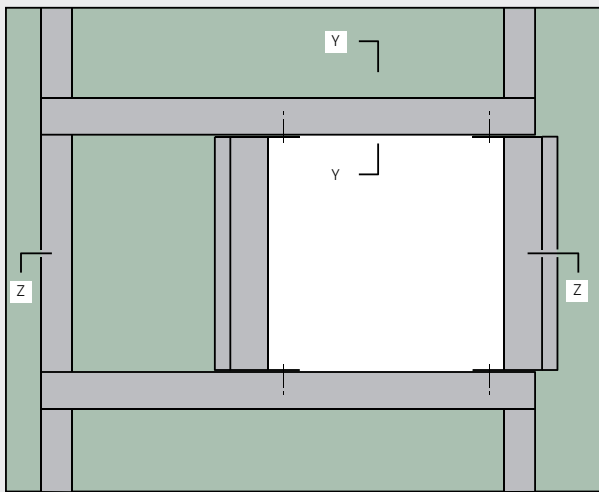

Section Z-Z

- 5
- 7
- 3
- 2
- 4
- 1
- 7

- 1 Gyproc FireStop
- 2 Gyproc CoreBoard
- 3 Gypframe 'I' Studs
- 4 Gypframe Retaining Channel
- 5 Gypframe Channel (to frame the opening)
- 6 Gyproc CoreBoard fire-stops (cut on site)
- 7 Access panel frame

## Construction details

20 Access door - spandrel panel

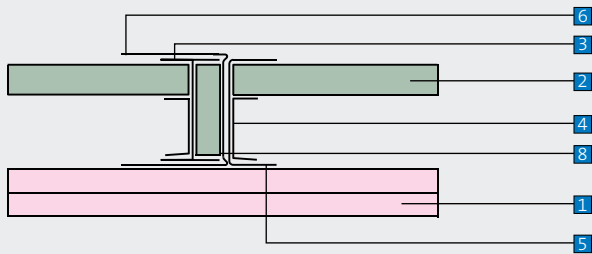

Lift door (Gypframe Starter Channel mechanically fixed to frame) 21

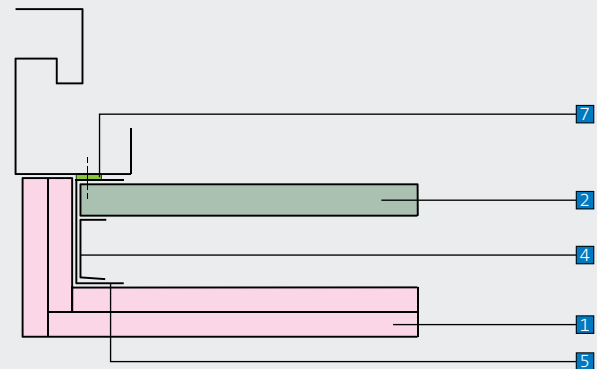

22 Access door jamb

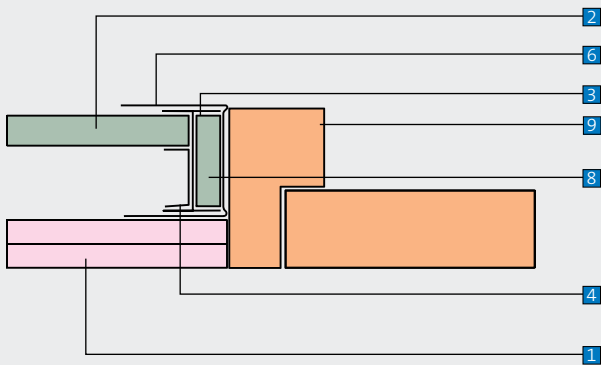

- 1 Gyproc FireStop
- 2 Gyproc CoreBoard
- 3 Gypframe 'I' Stud
- 4 Gypframe Retaining Channel
- 5 Gypframe Starter Channel

- 6 Gypframe Channel
- 7 Sealant
- 8 Gyproc CoreBoard packer (cut on site)
- 9 Door frame

# ShaftWall

## Construction details

23 Retro-fit non-performance partition junction

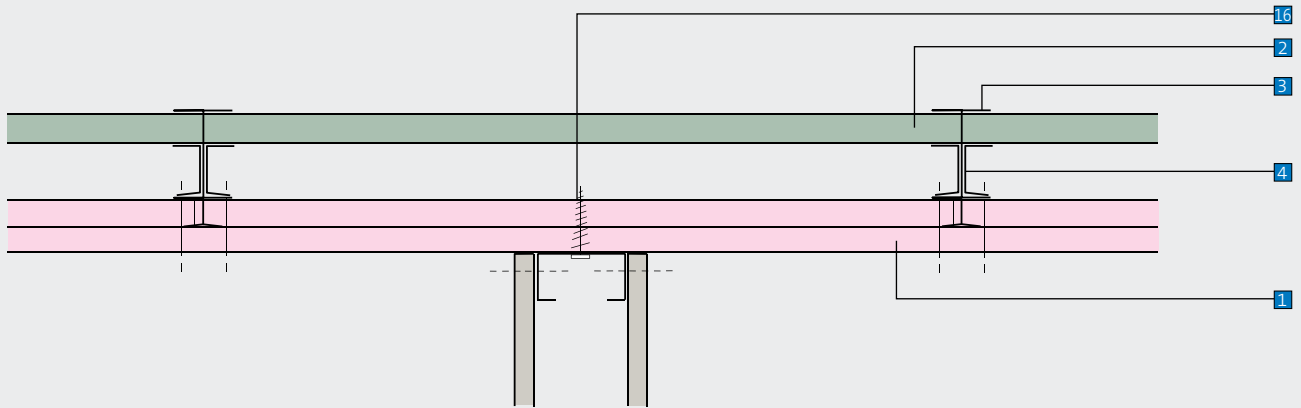

24 Fixing head channel to Z-section at underside of beams

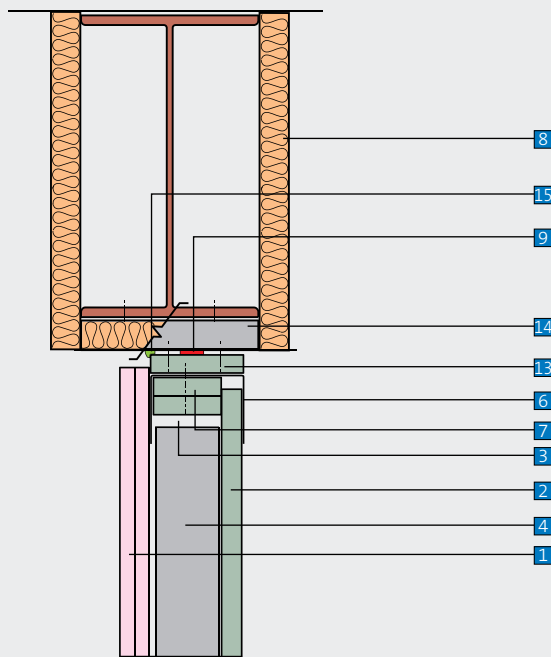

Movement joint at floor slab junction where lining boards continue 25

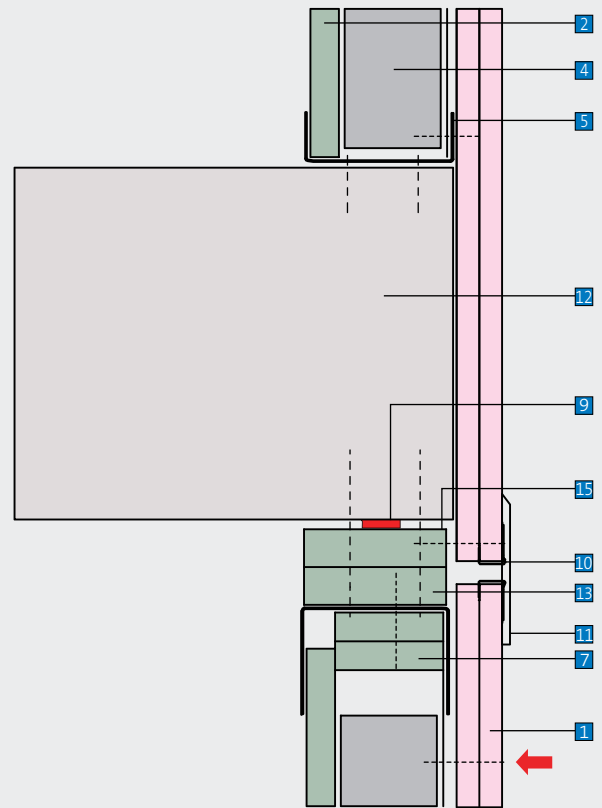

- 1 Gyproc FireStop
- 2 Gyproc CoreBoard
- 3 Gypframe 'I' Stud
- 4 Gypframe Retaining Channel
- 5 Gypframe Floor & Ceiling Channel
- 6 Gypframe Extra Deep Flange Floor & Ceiling Channel
- 7 Gyproc CoreBoard fire-stops
- 8 Beam encasement

- 9 Firestrip
- 10 Edge Bead - if no cover strip is used
- 11 Cover strip (by others)
- 12 Structure
- 13 Gyproc CoreBoard as dropped soffit
- 14 Z-section
- 15 Sealant by others
- 16 Suitable metal self-drive fixing (by others)

**NB** No fixings should be made through the boards into the flanges of the head channel. The arrow (➔) denotes the position of the uppermost board fixing.

