



# GYPFRAME METAL PROFILES

Technical & Safety Datasheet

## INTRODUCTION

### Characteristics

Gypframe profiles are designed for use in Gyproc drylining systems and are cold roll formed from DX51D + Z140 utilising the patented UltraSteel™ process.

### Protective coating

All Gypframe metal components are available with standard Zinc coating of Z140.\*

\*Also available in Z275 upon request.

### Cold Rolling and UltraSteel™

UltraSteel™ is a manufacturing process that alters the characteristics of plain steel, providing higher strength capacity at a lighter gauge. The process effectively hardens the steel by working it in strips with two mating rolls, which produce a dimpled surface and ribbing effect across the surface of the metal. During the process, the effective thickness of the material is increased to that of the original thickness plus that of the ribbing.

### Example

Base gauge= 0.5mm: after UltraSteel™ process= 1.0mm

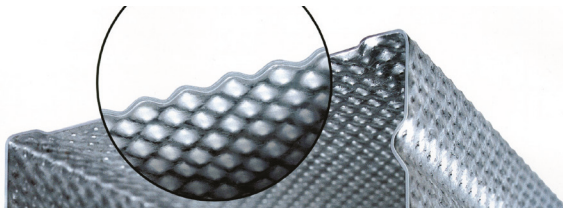

Once the UltraSteel™ process has been applied, the base material is then passed through a series of contoured rollers which progressively form the steel into the required profile. The number of rollers in the process will vary, depending on the complexity of the profile being rolled. Service entries or tabs are pierced, either at the beginning or end of this process. The formed profiles are then cut to exact length, packed and then bundled ready for delivery. UltraSteel™ is unique to Gyproc and the Gypframe product range. Along with an aesthetic difference, UltraSteel™ provides the following additional benefits over plain steel sections:

- Improved yield strength
- Improved load carrying capacity
- Improved screw retention and strip out strength
- Improved resistance to screw pull-out

## STANDARDS

Gypframe metal products are produced to the following manufacturing standards:

EN 14195:2005	EN 10162:2003	ASTM C645
---------------	---------------	-----------

All Gyproc system solutions listed in the Middle East WHITE BOOK are covered by the SpecSure system warranty designed to protect the integrity of Gyproc specifications and deliver reliable performance, unrivalled technical support and peace of mind for everyone involved in the construction team.

## RECYCLED CONTENT

Gypframe metal components are produced using steel manufactured by major world producers who use minimum 30% recycled ferrous scrap in producing the steel. Out of this 30% ferrous scrap:

- 80% is post-consumer recycled content
- 20% is pre-consumer recycled content

100% of Gypframe components are recyclable.

### Fixing

Gyproc Drywall Screws should be used for fixing Gyproc plasterboard to Gypframe metal, with the exception of Gyproc Habito plasterboard which should be fixed using Gyproc Habito Screws. Screw length should be based on board thickness and reaching a minimum of 10mm penetration into the metal framing.

### Example

Gyproc Plasterboard	Gyproc DryWall Screws mm				
1 x 12.5mm	25	35	42	55	75
1 x 15mm	25	35	42	55	75
2 x 12.5mm	25	35	42	55	75
2 x 15mm	25	35	42	55	75
3 x 12.5mm	25	35	42	55	75
3 x 15mm	25	35	42	55	75
4 x 12.5mm	25	35	42	55	75
4 x 15mm	25	35	42	55	75

It is important to select the right type of screw for the gauge (thickness) of Gypframe metal you are using.

### For fixing Gyproc plasterboard to Gypframe metal

Gyproc Drywall Screws	Gyproc Jack-Point Screws
Gypframe metal up to 0.8mm	Gypframe metal above 0.8mm and all 'I' Studs

### For fixing Gypframe metal to metal

Gyproc Wafer Head Screws	Gyproc Wafer Head Jack-Point Screws
Gypframe metal up to 0.8mm	Gypframe metal above 0.8mm and all 'I' Studs

Refer to Gyproc Screws data sheet for additional information

### Understanding Gypframe

The naming of Gypframe profiles follows a relatively simple nomenclature where the first 2 or 3 digits of a code refer to the component width, the letters refer to the component type and the last 2 digits indicate the gauge or metal thickness in mm. Several examples are listed in the table below. Other components also follow a simple 2 or 3 letter code with a further 1 or 2 digits to further identify the product. Examples would be RB1 - Resilient Bar 1, GA3 - Gypframe Angle 3, GFS1 - Gypframe Fixing Strap 1 and so on. Further information including descriptions, weights and dimensions are on the following pages.

Gypframe component			Description
Width	Type	Gauge	
70	S	50	70mm - 'C' Stud - in 0.5mm gauge
92	AS	50	92mm - AcouStud - in 0.5mm gauge
150	I	90	150mm - 'I' Stud - in 0.9mm gauge
100	FC	90	103mm - Fixing Channel - in 0.9mm gauge
52	C	50	52mm - Channel - in 0.5mm gauge
72	DC	60	72mm - Deep Channel - in 0.6mm gauge
102	EDC	80	102mm - Extra Deep Channel - in 0.8mm gauge

### Gypframe Studs

Used as the vertical support in wall framing, these products are available in a range of widths, lengths and gauge depending on requirements for strength, height, impact resistance and sound insulation. Profile drawings are on page 6 and 7.

### Gypframe 'C' Studs

The Gypframe 'C' Stud design includes sight lines down the legs of the stud to ease board alignment and increase profile strength. Structural apertures are also spaced along the spine of the Gypframe 'C' Stud, providing easy routing of services through the partition.

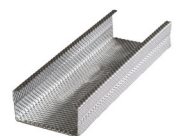

Product description	Width (mm)	Gauge thickness (mm <sup>1</sup> )	Available lengths (mm <sup>2</sup> )	Linear metre weight (kg)
50 S 50	50	0.5	3000	0.460
63 S 50	63	0.5	3000	0.500
70 S 50	70	0.5	3000	0.550
73 S 50	73	0.5	3000	0.550
92 S 50	92	0.5	3000	0.640
100 S 50	100	0.5	3000	0.670
150 S 50	150	0.5	3000	0.820

1. Also available in increased gauge upto 0.9mm with increments of 0.1mm. 92mm C stud is also available 1.0 mm gauge thickness.
2. Bespoke lengths available on request.

### Gypframe 'I' Studs

These studs are the strongest available in the Gypframe range. They allow for increased partition height, without increasing partition width, and provide improved impact resistance. Commonly used in ShaftWall, GypLyner iwl, GypWall quiet iwl and other GypWall systems where board fixing strength is paramount. Structural apertures are also spaced along the spine of the Gypframe 'I' Stud, providing easy routing of services through the partition.

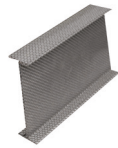

Product description	Width (mm)	Gauge thickness (mm <sup>1</sup> )	Available lengths (mm <sup>2</sup> )	Linear metre weight (kg)
70 I 70	70	0.7	3000	1.080
100 I 80	100	0.8	3000	1.420
150 I 90	150	0.9	3000	1.640

1. Also available in 0.9 mm gauge thickness.
2. Bespoke lengths available on request.

### Gypframe AcouStuds

These unique shaped studs are used for increased acoustic performance. The innovative patented profile reduces sound energy as it passes through the partition. Gypframe AcouStuds are available in both 70mm and 92mm sizes and can upgrade the acoustic performance of your partition without using insulation. The Gypframe AcouStud design includes sight lines for both board alignment and added profile strength. Gypframe AcouStuds also have wider flange widths than Gypframe 'C' Studs, providing increased board fixing area.



Product description	Width (mm)	Gauge thickness (mm)	Available lengths (mm <sup>1</sup> )	Linear metre weight (kg)
70 AS 50	70	0.5	3000	0.760
92 AS 50	92	0.5	3000	0.850

1. Bespoke lengths available on request.

### Gypframe Standard, Deep and Extra Deep Channel

These products are used for retaining Gypframe studs at floor and ceiling junctions. Standard channels are used for partition heights of up to 4200mm, Deep Flange (DC) and Extra Deep Flange (EDC) versions are available for partitions over 4200mm high and 8000mm high respectively, or in situations where easier fixing of skirting is required, for deflection head details and improved impact resistance. Profile drawings are on page 6 and 7.

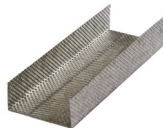

Product description	Width (mm)	Gauge thickness (mm <sup>1</sup> )	Available lengths (mm <sup>2</sup> )	Linear metre weight (kg)
52 C 50	52	0.5	3000	0.365
65 C 50	65	0.5	3000	0.413

72 C 50	72	0.5	3000	0.460
75 C 50	75	0.5	3000	0.480
94 C 50	94	0.5	3000	0.540
102 C 50	102	0.5	3000	0.560
152 C 50	152	0.5	3000	0.734

1. Also available in increased gauge upto 0.9mm with increments of 0.1mm.
2. Bespoke lengths available on request.

### Gypframe Deep Channels

Deep (DC) Channels are used for partition heights between 4200mm and 8000mm or in situations where easier fixing of skirting is required, for deflection head details and improved impact resistance.

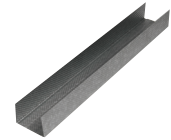

Product description	Width (mm)	Gauge thickness (mm <sup>1</sup> )	Available lengths (mm <sup>2</sup> )	Linear metre weight (kg)
52 DC 60	52	0.6	3000	0.701
65 DC 60	65	0.6	3000	0.751
72 DC 60	72	0.6	3000	0.791
75 DC 60	75	0.6	3000	0.831
94 DC 60	94	0.6	3000	0.930
102 DC 60	102	0.6	3000	0.940
152 DC 60	152	0.6	3000	1.177

1. Also available in increased gauge upto 0.9mm with increments of 0.1mm.
2. Bespoke lengths available on request.

### Gypframe Extra Deep Channels

Extra Deep (EDC) Channels are used for partition heights over 8000mm or in situations where easier fixing of skirting is required, for deflection head details and improved impact resistance.



Product description	Width (mm)	Gauge thickness (mm <sup>1</sup> )	Available lengths (mm <sup>2</sup> )	Linear metre weight (kg)
52 EDC 80	52	0.8	3000	1.188
65 EDC 80	65	0.8	3000	1.313
72 EDC 80	72	0.8	3000	1.357
75 EDC 80	75	0.8	3000	1.376
94 EDC 80	94	0.8	3000	1.490
102 EDC 80	102	0.8	3000	1.545
152 EDC 80	152	0.8	3000	1.860

1. Also available in 0.9mm gauge thickness.
2. Bespoke lengths available on request.

### Gypframe MF Ceiling Channels and Accessories

These channels and associated accessories are designed for providing seamless suspended ceilings that can be either flat or curved. Profile drawings are on page 6, 7 and 8.



Product description	Width (mm)	Gauge thickness (mm)	Available lengths (mm <sup>2</sup> )	Linear metre weight (kg)
MF5 (Furring section)	35	0.5 <sup>1</sup>	3000	0.367
MF7 (Main Channel)	38	0.5 <sup>1</sup>	3000	0.230
GA1 Angle	25 x 25	0.5 <sup>1</sup>	3000	0.190
Soffit Cleat with Nut & Bolt	25	1.6	N/A	N/A
Main Channel Clip	41.56	2.5	N/A	0.007

1. Also available in increased gauge upto 0.9mm with increments of 0.1mm. MF7 and GA1 also available in 1.5mm gauge thickness.
2. Bespoke lengths available on request.

## Gypframe Clip-in Channels and Accessories.

These channels and associated accessories are designed for suspended Gyproc Clip-in Metal Ceiling System. Profile drawings are on page 6.

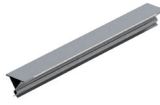

Product description	Width (mm)	Gauge thickness (mm)	Available lengths (mm)	Linear metre weight (kg)
Spring T	35	0.45	4000	0.401
Main Channel Clip	41.56	2.5	-	0.007

## GypLyner Studs and Accessories

This range of studs and accessories is designed for the ease of installing plasterboard linings on masonry walls, concrete soffits, and the encasement of steel columns and beams. Profile drawings on page 6 and 7.

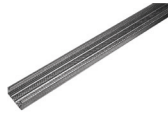

Product description	Width (mm)	Gauge thickness (mm)	Available lengths (mm <sup>2</sup> )	Linear metre weight (kg)
GL1 Stud	38	0.5 <sup>1</sup>	3000	0.263
GA1 Angle	25 x 25	0.5 <sup>1</sup>	3000	0.190
GLB85 Fixing Bracket	30	0.8	N/A	N/A
GLB135 Fixing Bracket	30	0.8	N/A	N/A

1. Also available in increased gauge upto 0.9mm with increments of 0.1mm.
2. Bespoke lengths available on request.

## ShaftWall Channels and Accessories

This range of channels and compatible accessories is designed especially for the high performance ShaftWall system. 70mm 'I' Stud ShaftWall system uses 70 SC 70 Starter Channel & RC70 Retaining Channel. 100mm 'I' Stud ShaftWall system uses 100 SC 80 Starter Channel and RC100 Retaining Channel. 150mm 'I' Stud ShaftWall system uses 150 SC 90 Starter Channel and RC150 Retaining Channel. Profile drawings are on page 6 and 7.

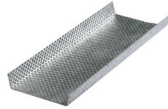

Product description	Width (mm)	Gauge thickness (mm)	Available lengths (mm <sup>2</sup> )	Linear metre weight (kg)
70 SC 70	70	0.7 <sup>1</sup>	3000	0.687
100 SC 80	100	0.8 <sup>1</sup>	3000	0.980
150 SC 90	150	0.9	3000	1.450
RC70	45	0.4	3000	0.280
RC100	73	0.5	3000	0.392
RC150	35	0.4	3000	0.283
GA3 Angle	32 x 19	0.6 <sup>1</sup>	3000	0.300

1. Also available in increased gauge upto 0.9mm with increments of 0.1mm.
2. Bespoke lengths available on request.

## Performance Accessories for Gyproc Acoustic Systems

These specially engineered products are used to optimise acoustic performance in partition wall systems.

Product description	Width (mm)	Gauge thickness (mm)	Available lengths (mm)	Linear metre weight (kg)
Gypframe RB1 Resilient Bar	16	0.45	3000	0.390
GAB3 Gypframe Acoustic Brace	-	-	459/pair	8/box

## Gypframe Steel Angles

Widely used in framed construction to provide support, fixing and additional strength to wall, ceiling and encasement framing. Profile drawings are on page 6 and 7.

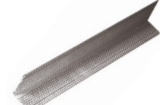

Product description	Width (mm)	Gauge thickness (mm)	Available lengths (mm <sup>2</sup> )	Linear metre weight (kg)
GA1 Angle	25 x 25	0.5 <sup>1</sup>	3000	0.190
GA3 Angle	32 x 19	0.6 <sup>1</sup>	3000	0.270
GA4 Angle	50 x 25	0.7 <sup>1</sup>	3000	0.440
GA6 Splayed Angle	86.5 x 86.5	0.5	3000	0.670
GA7 Angle	70 x 25	0.8	3000	0.610

1. Also available in increased gauge upto 0.9mm with increments of 0.1mm.
2. Bespoke lengths available on request.

## Gypframe Fixing Strap and Channels

Fixing Strap is used to maintain board fixings along horizontal joints in multilayer boarded systems. Fixing Channel's provide added support for fixtures and fittings, and Service Support Plates allow for the positioning of 18mm plywood within the cavity behind the plasterboard lining for heavy weight fixtures.



Product description	Width (mm)	Gauge thickness (mm)	Available lengths (mm <sup>2</sup> )	Linear metre weight (kg)
GFS1 Fixing Strap	70	0.40	2400 3000	0.260
103 FC 50 Fixing Channel	103	0.50	2400	0.390
103 FC 90 Fixing Channel	103	0.90	2400	0.680
153 FC 90 Fixing Channel	153	0.90	2400	0.990
Service Support plate	106	0.60	130	0.100/per pc

1. Bespoke lengths available on request.
- Note: All products listed above are supplied in plain steel

## Gypframe High Strength Security Sheets

Specifically designed integral part of the GypWall SECURE system for providing resistance against burglary and attack, to safeguard property and assets in high security buildings.

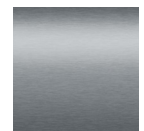

Product description	Width (mm <sup>1</sup> )	Available lengths (mm)
SR2-1	1200	1000
SR3-2	1200	1000
SR3-1	1200	1000

## Plasterboard Metal Accessories

A range of beads for use with plasterboard to provide corner and edge reinforcement and protection.

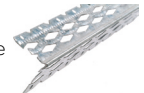

Product description	Width (mm)	Gauge thickness (mm)	Available lengths (mm <sup>1</sup> )	Linear metre weight (kg)
Corner Bead 25x25mm	25x25	0.4	3000	0.109
Corner Bead 31x31mm	31x31	0.4	3000	0.140
Edge Bead 12.5mm	10x12.5x25	0.4	3000	0.150
Edge Bead 15mm	10x15x25	0.4	3000	0.160

1. Bespoke lengths available on request.

GYPFRAME PROFILES

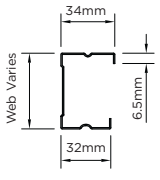
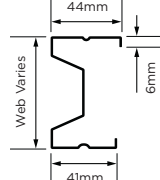
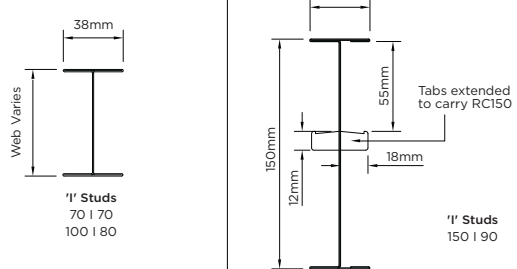
Gypframe 'C' Studs	Gypframe AcouStuds	Gypframe 'I' Studs
 <p>50 S 50    63 S 50 70 S 50    73 S 50 92 S 50    100 S 50 150 S 50</p>	 <p><b>AcouStuds</b> 70 AS 50 92 AS 50</p>	 <p><b>'I' Studs</b> 70 I 70 100 I 80</p> <p><b>'I' Studs</b> 150 I 90</p>

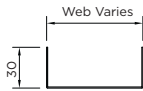
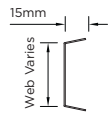
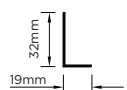

ShaftWall Channels and Accessories

 <p><b>Starter Channel</b> 70 SC 70 100 SC 80 150 SC 90</p>	 <p><b>Retaining Channel</b> RC 70 RC 100 RC 150</p>	 <p><b>GA3 Steel Angle</b></p>
--	---	---

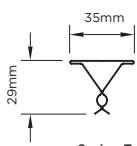
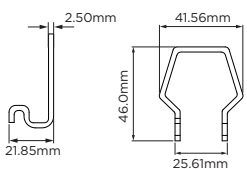
Gypframe Clip-in Channels and Accessories

 <p><b>Spring T</b></p>	 <p><b>Main Channel Clip</b></p>
--	--

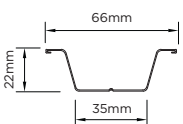
Gypframe MF Ceiling sections

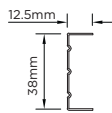
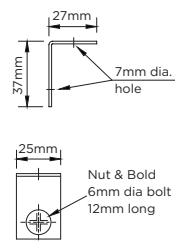
 <p><b>MF5 Ceiling Section</b></p>	 <p><b>GA1 Steel Angle</b></p>	 <p><b>MF7 Primary Support Channel</b></p>	 <p><b>Gypframe Soffit Cleat with Nut &amp; Bolt</b></p>
---	---	--	---

Gypframe Standard, Deep and Extra Deep Channels

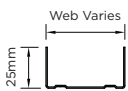
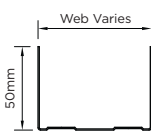
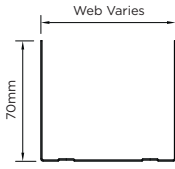
 <p><b>Standard 'C'</b> 52 C 50    65 C 50 72 C 50    75 C 50 94 C 50    102 C 50 152 C 50</p>	 <p><b>Deep Channel 'DC'</b> 52 DC 60    65 DC 60 72 DC 60    75 DC 60 94 DC 60    102 DC 60 152 DC 60</p>	 <p><b>Extra Deep Channel 'EDC'</b> 52 EDC 80    65 EDC 80 72 EDC 80    75 EDC 80 94 EDC 80    102 EDC 80 152 EDC 80</p>
---	---	---

GYPFRAME PROFILES

GypLyn® sections

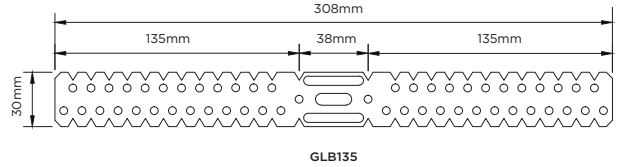
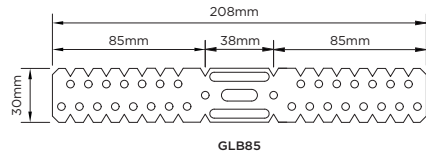

GypLyn® sections

Fixing Channels

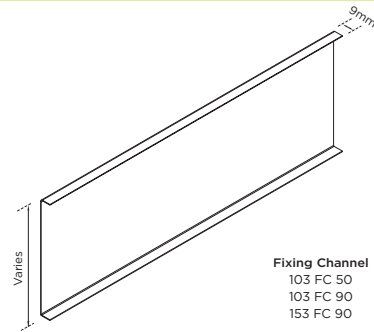
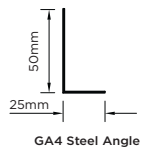
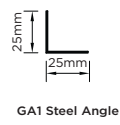
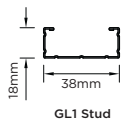

Service Support Plate

Fixing Strap

RB1 Resilient Bar

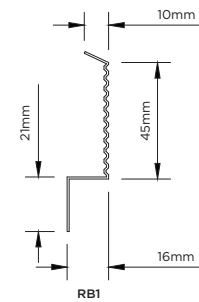
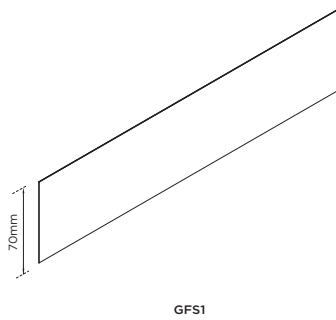
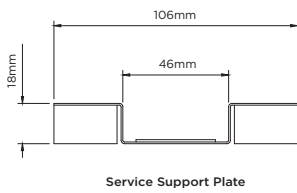

Gypframe Angles

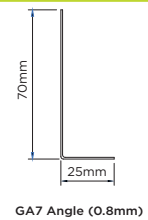
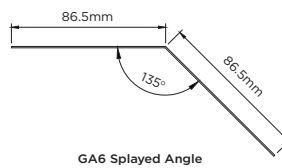
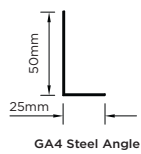
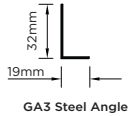
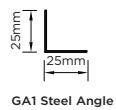

Edge Bead

Corner Bead

GAB3 Acoustic Base

Gypframe Security Sheet

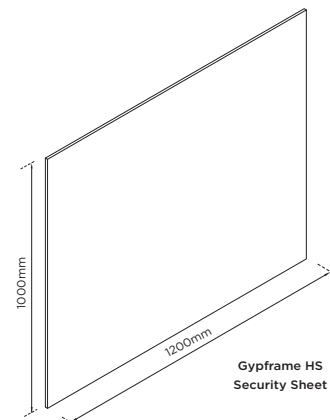
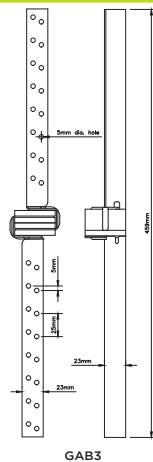
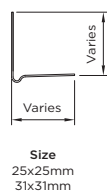
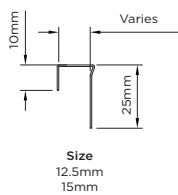

### 1. Identification of the substances/preparation and company

#### Product name

Manufacturer: Saint-Gobain Gyproc Emirates Industries L.L.C  
ICAD 1, Mussafah  
Abu Dhabi  
United Arab Emirates  
P.O. Box 38983  
Free Phone: 800 Gyproc (497762)  
E-Mail: gyproc-me@saint-gobain.com

Recommended uses: In conjunction with Gyproc plasterboards to form internal walls and ceiling systems, linings and encasements.

### 2. Composition/Information on ingredients

General composition: Mild steel sections coated by zinc electrolytic process or hot dip galvanised process. The sections may have a protective film of a roll forming hydrocarbon lubricant or a residue of cutting fluid.

### 3. Hazards identification

THE MOST IMPORTANT HAZARDS ARE:

These products are not classified as dangerous according to CLP. CLP is the law that applies to suppliers of dangerous chemicals. Its purpose is to protect people and the environment from the effects of those chemicals by requiring suppliers to provide information about the dangers and to package them safely.

There is a risk of cuts and abrasions from sharp edges and ends when handling metal sections and in use where they have been fitted to floors or walls and are exposed, prior to fixing plasterboard.

There is also a risk when cutting the banding due to the release of tension and the potential movement of material. Repeated contact with sheet metal coatings may cause skin irritation. During power cutting, grinding or drilling, irritant fumes or dust may be produced which can cause metal fume fever.

### 4. First aid measures

Eye contact	Seek medical attention and treatment.
Skin contact	Wash thoroughly with soap and water.
Ingestion	Seek medical attention and treatment.
Inhalation	If irritation persists, remove person to fresh air.
General	Get medical attention if any symptoms persist.

### 5. Fire fighting measures

The products do not pose a fire hazard. However, the protective coating/lubricant, packaging banding or sponge rubber elements may be combustible and emit hazardous fumes.

Suitable extinguishing media - foam, carbon dioxide, dry powder.

### 6. Accidental release measures

Product discarded in an unaltered form is classified as a non-hazardous waste.

### 7. Handling and storage

Mechanical handling - The dimensions of the pallet vary depending upon the product size. To avoid potentially overloading a lift truck, it is important that any effect on load centres is considered. The nominal weight of each palletised load is given on the delivery note.

Manual handling - Metal sections are supplied in a variety of lengths and widths and the weight of different sections varies. Do not use the banding or straps for lifting. Carefully consider the manual handling risks before lifting sections of metal. Appropriate cut-resistant PPE should be used when handling metal sections.

Storage - Store on pallets supplied and in dry conditions. To maintain stability, place pallets on firm level ground and ensure that stacks are both level and vertical. Stack height should not exceed twice the width of the pack. Banding should only be removed at ground level.

Use - Caution: as with all cut metal products, there is risk from sharp corners or edges. Appropriate cut-resistant PPE should be used when handling metal sections. Avoid prolonged and repeated contact with skin and wear protective clothing when handling metal sections (see Section 8).

When the banding is cut it may spring back as tension is released and the pack of material may become unstable. Appropriate PPE (including eye protection to BS EN 166) should be worn.

Metal sections which have been fixed to the floor or side wall, ready for plasterboard fixing, may have exposed sharp edges and care should be taken to protect persons from unintentional contact. Exposure to potentially sharp edges should be minimised.

Metal sections are not designed to support body weight; fixers must work from an independent support system.

### 8. Exposure control/personal protection

Respiratory	Use in a well ventilated area. Wear approved respiratory equipment when power cutting or grinding.
Skin	Wear cut resistant gloves, suitable overalls and footwear when handling sections.
Eye	If there is a risk of material entering the eye, wear eye protection to BS EN 166.

### 9. Physical and chemical properties

Appearance	Metal sections in various lengths, thicknesses and formation.
Odour	Paraffin/oil (protective coating).

### 10. Stability and reactivity

Stable under normal conditions but when subjected to high temperatures fumes are produced.

### 11. Toxicology information

Inhalation	Dry grinding or machining may produce dust of the same composition as the coating and base metal. Flame cutting may produce fumes containing oxides of zinc and iron, and also breakdown products of protective coating. Potential effects health include metal fume fever, a condition similar to influenza.
Skin contact	Prolonged and repeated contact may cause irritation
Eye contact	None in normal use.
Ingestion	Not applicable.

### 12. Ecological information

Stable product with no known adverse environmental effects.

### 13. Recycling

Gypframe Metal components contain recycled content and can contribute to LEED NC v2.2 Credit MRc4: Recycled Content.

### 14. Disposal consideration

Dispose at an authorised metal recycling facility in accordance with local waste management licensing regulations.

### 15. Transport information

Not classified as hazardous for transportation.

### 16. Regulatory information

Not classified under the CHIP regulations.

### 17. Other information

Note to User:

This Product Data Sheet does not constitute a workplace risk assessment for COSHH.

There are a number of situations where the approach to manual handling of Gyproc products should be considered. For further guidance, please refer to the Manual Handling Section of the Gyproc Middle East WHITE BOOK, or contact Gyproc technical department.





**SAINT-GOBAIN**

**Saint-Gobain Gyproc Middle East FZE**  
P.O.Box.261107, Dubai  
Tel: +971 4 814 3666

**Saint-Gobain Gyproc Emirates Industries LLC**  
P.O. Box 38983, ICAD 1, Mussafah, Abu Dhabi  
Tel: +971 2 557 1929



Saint-Gobain  
Gulf Countries



Saint-Gobain  
Gulf Countries



Saint-Gobain  
Gulf Countries

November 2024